



Submersible Pumps & Float Switches

1.5 inch and 2 inch Pumps, 1/3 HP to 1 HP:

- **Light Weight Slim Design**
- **Thermal Overload Protected**
- **Lower Seal: Silicon-carbide, Viton®**
Upper Seal: Carbon Ceramic, Viton®
- **Oil Lubricated Seals, Nitrile O-rings**
- **Cast Iron Impeller, Top, Pump End**
- **304 Stainless Steel Casing, Motor Housing, Shaft and Hardware**
- **Long Power Cables-30 ft. On 1/3 HP & 1/2 HP and 50 ft. On 1 HP**
- **Optional Piggyback Mercury-free Float Switches**



1 1/2XT33, 2XH5, 2X11



Piggyback Float Switch 55-930

Slim-design, light weight CSA listed submersibles feature top discharge as well as cast-iron impellers, 304 stainless steel casing, motor housing, shaft and hardware. Pump motor is thermal overload protected. An optional piggyback mercury-free float switch is available. Float Switches: The mercury free liquid level control has a piggyback plug molded to the cord allowing the pump motor to plug into the cord and then plug the entire assembly into a standard grounded outlet.

Viton® is a registered trademark of E.I. DuPont

Performance of Submersible Pumps

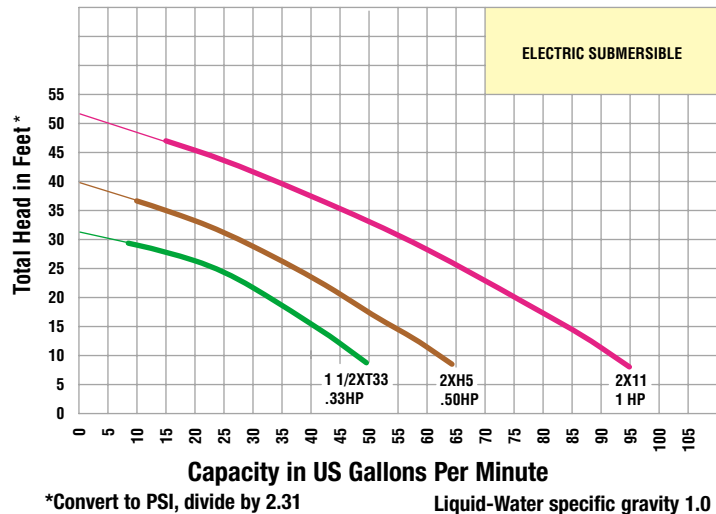

Submersible Pumps & Float Switches

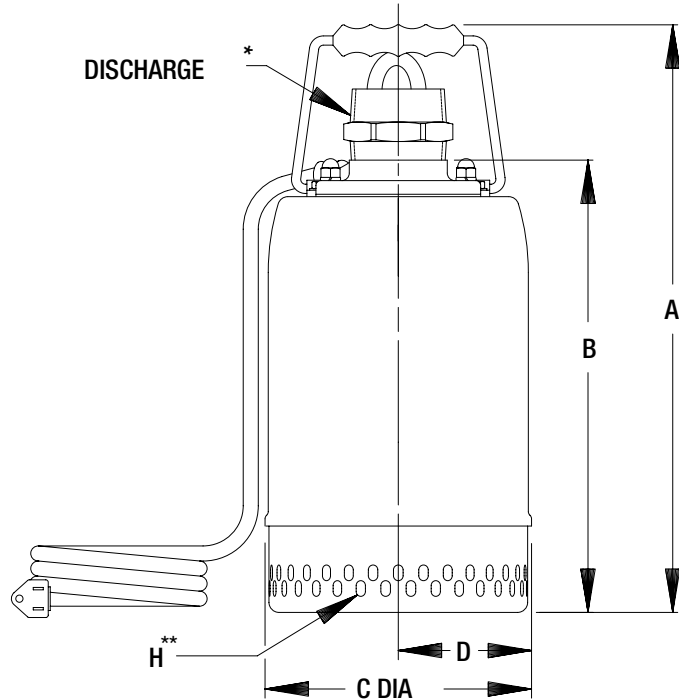
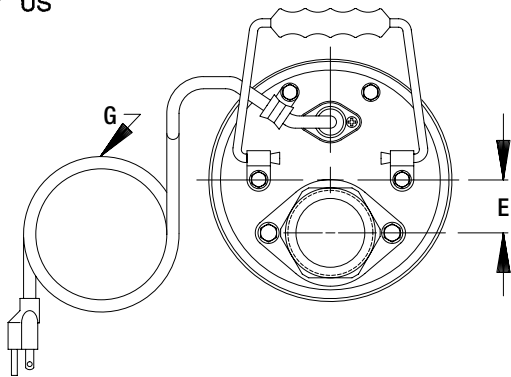

** Minimum Liquid Height 3"

DIMENSIONS:
INCHES
[MILLIMETERS]

MODEL	A	B	C	D	E	DISCH *	G CABLE LENGTH	H ** SUCTION STRAINER
11/2XT33	14.50 [368.3]	11.25 [285.8]	6.66 [169.2]	3.33 [84.6]	1.44 [36.6]	1.50	30.00 FT/[9.1 M]	.39/[9.9] X .24/[6.1] SLOTS ON .31/[7.9] STAGGERED CENTERS
2XH5	14.50 [368.3]	11.13 [282.7]	6.66 [169.2]	3.33 [84.6]	1.44 [36.6]	2.00	30.00 FT/[9.1 M]	.39/[9.9] X .24/[6.1] SLOTS ON .31/[7.9] STAGGERED CENTERS
2X11	17.12 [434.8]	13.75 [349.2]	7.55 [191.8]	3.80 [96.5]	1.64 [41.6]	2.00	50.00 FT/[15.2 M]	.25/[6.4] X .38/[9.6] SLOTS ON .50/[12.7] STAGGERED CENTERS

(*) STANDARD NPT (MALE) PIPE THREAD.

(**) Minimum Liquid Height 3"

Model No.	Description/ Type of Pump	Ship Wt (Lbs.)	Driver Type & HP	Port size Suc x dis (NPT)	Basic Construction	VAC or Tank Size (Qts.)	FL Amps
11/2XT33	Submersible Pump	30	1/3 HP	1.5"	Stainless Steel/Cast Iron	115V	2.8
2XH5	Submersible Pump	31	1/2 HP	2"	Stainless Steel/Cast Iron	115V	5.4
2X11	Submersible Pump	50	1 HP	2"	Stainless Steel/Cast Iron	115V	9.3
55-930	Float Switches-30 ft.*					115V	13
55-950	Float Switches-50 ft.*					115V	20

*Float Switches: 55-930 Electrical rating 115/13 Amps. 30 ft. 16 ga. Cord. Used on Model 1 1/2XT33 and 2XH5 Pumps. 55-950 Electrical rating 115/20 Amps. 50 ft. 14 ga. Cord. Used on Model 2X11

Submersible Pump Standard Features

- Light Weight slim design
- Motors Protected by overload or thermal breaker
- Lower seal-silicon-carbide, upper seal-carbon ceramic, Viton®
- Oil lubricated seals
- Cast iron impeller, top, pump end
- 304 Stainless steel casing, motor housing, shaft and hardware
- Long power cables-30 ft. on 1/3 HP & 1/2 HP and 50 ft. on 1 HP
- Optional piggyback mercury-free float switches
- Nitrile O-rings

Float Switch Standard Features

- Mercury-Free
- No Wiring
- Adjustable Clamp
- Corrosion Resistant
- Proven Reliability
- Omni Directional
- Variable Pumping Range
- Easily Installed

WARNING: Do not use in explosive atmosphere or for pumping volatile flammable liquids.

See price book page 39

The Gorman-Rupp Company reserves the right to discontinue any model or change specifications at any time without incurring any obligation.



CP95-96/1006